

1515Design

The Art of Rotisserie since 1963



PRODUCT GUIDE



WWW.1515DESIGN.COM
Made in France





MAG SERIES SPIT ROTISSERIES



MAG 40/6 Gas

W: 43" D: 27 1/4" H: 77 1/2" (with cart)
24 to 30 chickens/hour
6 Burners - 84,000 BTU /hr (Natural Gas)



MAG 40/8 Gas

W: 43" D: 27" H: 77 1/2"
32 to 40 chickens/hour
8 Burners - 112,000 BTU /hr (Natural Gas)



MAG 58/4 Gas

W: 58 1/4" D: 27" H: 77 1/2" (with cart)
24 to 28 chickens/hour
4 Burners - 72,200 BTU/hr (Natural Gas)



MAG 58/6 Gas

W: 58 1/4" D: 27" H: 77 1/2" (with cart)
36 to 42 chickens/hour
6 Burners - 147,400 BTU/hr (Natural Gas)



MAG 58/8 Gas

W: 58 1/4" D: 27" H: 77 1/2"
48 to 56 chickens/hour
8 Burners - 195,000 BTU/hr (Natural Gas)



MAG 6 Gas

W: 58 1/4" D: 27" H: 77 1/2"
30 chickens/hour on basket spits
6 Burners - 147,400 BT/hr (Natural Gas)



MAG 40/8 Electric

W: 43 1/4" D: 27" H: 77 3/4"
32 to 40 chickens/hour
208 V Triphase - 25 Kw - 69.4 A



MAG 58/4 Electric

W: 58 1/4" D: 25" H: 77 3/4" (cart)
24 to 28 chickens/hour
208 V Triphase - 20.6 Kw - 54 A



MAG 58/6 Electric

W: 58 1/4" D: 25 1/2" H: 77 3/4" (cart)
36 to 42 chickens/hour
208 V Triphase - 29.5 Kw - 77.4 A



MAG 58/8 Electric

W: 58 1/4" D: 24 3/4" H: 77 3/4"
48 to 56 chickens/hour
208 V Triphase - 40.3 Kw - 111.1 A



MAGFLAM SERIES SPIT ROTISSERIES



MAGFLAM 40/3 Gas

W: 43" D: 27" H: 37 1/4" (without cart)
12 to 15 chickens/hour
1 Burner - 30,000 BTU/hr (Natural Gas)



MAGFLAM 40/5 Gas

W: 43" D: 27" H: 51 1/2" (without cart)
15 to 20 chickens/hour
2 Burners - 60,000 BTU/hr (Natural Gas)



MAGFLAM 40/8 Gas

W: 43" D: 27" H: 76 1/2"
24 to 32 chickens/hour
3 Burners - 112,000 BTU/hr (Natural Gas)



MAGFLAM 58/3 Gas

W: 58 1/4" D: 25" H: 70 1/2" (with cabinet)
18 to 21 chickens/hour
1 Burner - 41,000 BTU/hr (Natural Gas)



MAGFLAM 58/5 Gas

W: 58 1/4" D: 27" H: 51 1/2" (without cart)
30 to 35 chickens/hour
2 Burners - 82,000 BTU/hr (Natural Gas)



MAGFLAM 58/8 Gas

W: 58 1/4" D: 27" H: 77 3/4"
48 to 56 chickens/hour
3 Burners - 132,000 BTU/hr (Natural Gas)

CUSTOM COLORS AVAILABLE UPON REQUEST
MAG AND MAGFLAM SERIES





BASKET ROTISSERIES



DECO RB 15 Electric

W: 34 1/4" D: 30 3/4" H: 34 1/2"
5 Baskets - 15 chickens/hour
208 V Triphase - 6.7 Kw - 18.6 Amps



DECO RB 20 Electric

W: 45" D: 32" H: 38 1/4"
5 Baskets - 20 chickens/hour
208 V Triphase - 9.1 Kw - 25.3 Amps



DECO RB 30 Electric

W: 45" D: 32" H: 38 1/4"
6 Baskets - 30 chickens/hour
208 V Triphase - 10 Kw - 27.8 Amps



NEOGRILL N1 Electric

W: 33 1/2" D: 28 1/3" H: 30 1/2"
4 Baskets - 16 chickens/hour
208 V Triphase - 7.6 Kw - 21.1 Amps



NEOGRILL N2 Electric

W: 40 1/2" D: 19" H: 68 1/4"
4 Baskets - 24 chickens/hour
208 V Triphase - 10 Kw - 27.8 Amps



STEAMBOX Electric

W: 33 3/4" D: 30 1/2" H: 35"
4 Baskets - 12 to 16 chickens/hour
208V Triphase - 9 Kw - 25 Amps



MODEL 6 Electric

W: 40 1/2" D: 30 5/8" H: 37 3/4"
20 to 30 chickens/hour
208 V Triphase - 9.5 Kw - 26.4 Amps



MODEL 9 Electric

W: 40 1/2" D: 37 3/4" H: 43"
30 to 45 chickens/hour
208 V Triphase - 13.5 Kw - 37.5 Amps



VENTLESS HOOD S4

For models N1, N2, N2 stacked and Neol
W: 33 1/2" D: 32 1/2" H: 10 1/2"
208 V Single Phase - 0.2 Kw - 1.74 Amps



CONCEPTS AND HEATED DISPLAYS



NEO2 STACKED Electric
 W: 42" D: 25 1/2" H: 72 3/4"
 8 Baskets - 48 chickens/hour
 220 V Triphase - 10Kw - 52 Amps



NEOL Electric
 W: 33 3/4" D: 37 3/4" H: 76"
 4 Baskets - 16 chickens/hour
 220 V Triphase - 10.2 Kw - 26.7 Amps



NEOBOX Electric
 W: 33 3/4" D: 37 3/4" H: 78 3/4"
 4 Baskets - 16 chickens/hour
 220 V Triphase - 11.6 Kw - 30.6 Amps



MODEL 6 STACKED Electric
 W: 40 1/2" D: 30 5/8" H: 76 5/8"
 40 to 60 chickens/hour
 208 V Triphase (x2) - 2x11.5 Kw - 2x31.9 Amps



V 60 LS5 PULSE
 W: 23 1/2" D: 31 1/2" H: 78 1/2"
 220 V Single Phase - 4.2 Kw - 18.3 Amps



V 100 LS5 PULSE
 W: 39 1/2" D: 31 1/2" H: 78 1/2"
 208 V Triphase - 6.8 Kw 18.9 Amps



SPIT ROTISSERIES ACCESSORIES



AC 13
English Spit
For MAG / MAGFLAM Series



AC 15
Spit with Prongs
For MAG / MAGFLAM Series



AC 16
Basket for back of Knee or Shin
For MAG / MAGFLAM Series



AC 17
Basket for large Meat pieces
For MAG / MAGFLAM Series

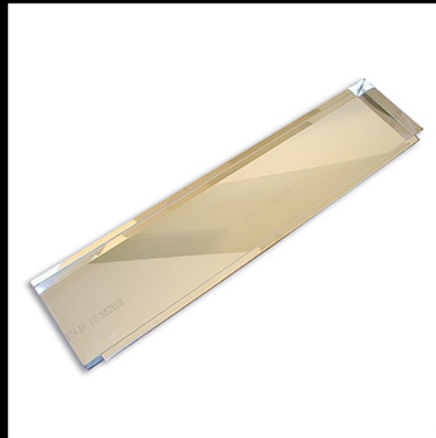

AC 18
Middle Tray Pan
For MAG / MAGFLAM Series



AC 20
V-Spit
For MAG / MAGFLAM Series



AC 20
Simplifil Spit
For MAG / MAGFLAM Series



AC 21
Basket for Multipurpose usage
For MAG / MAGFLAM Series



AC 22
Prep Rack 10 Spits
For MAG / MAGFLAM Series



BASKET ROTISSERIES ACCESSORIES

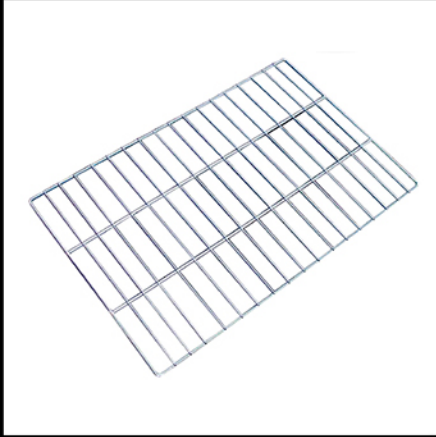

AC 5
Cooking Shelf



AC 9
Roasting Tin

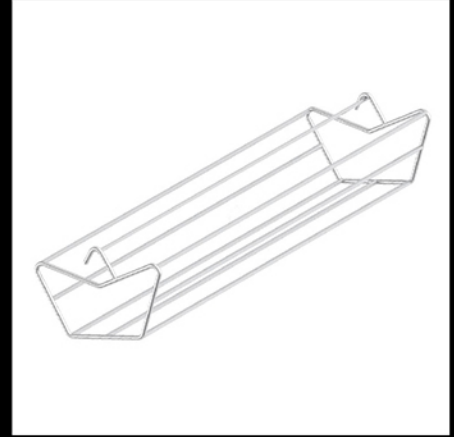

AC 11
Basket for Big Pieces

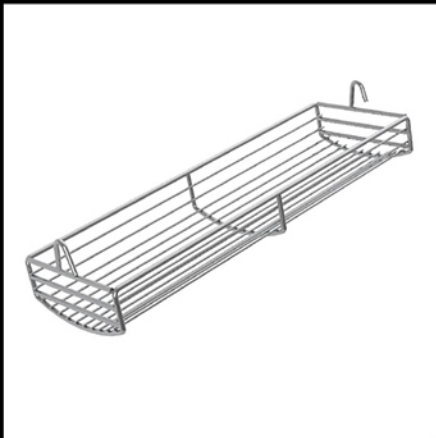

AC 12
Leg Basket



AC 45
Fork Spit for Large Meat Pieces



AC 46
Tightening Spit for Large Meat Pieces



AC 26
Large Tray

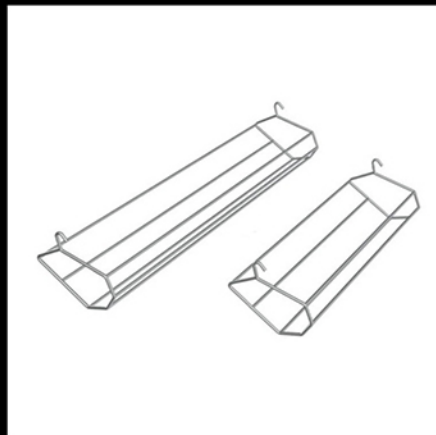

AC 28
Regular Basket



WWW.1515DESIGN.COM

Commercial Rotisseries & Heated Displays



1515Design

405 N. Oak Street, Inglewood CA 90302

Toll free (888) 671 0360 - Tel. (310) 671 0345 - Fax (310) 680 2879

E-mail: info@1515design.com - Website: www.1515design.com